

TCG 250 Floor Grinder

Operation and Maintenance Manual



TRELAWNYTM
SURFACE PREPARATION TECHNOLOGY

www.trelawnyspt.co.uk

OPERATION

Foreword

Thank you for your purchase of the TRELAWNY TCG250 Floor Grinder.

This manual contains the necessary maintenance information for you to ensure proper operation and care for this machine.

See also the manual that is supplied by the engine manufacturer.

It is essential for you to read through these manuals thoroughly.

In the unlikely event that you experience problems with your TCG250, please do not hesitate to contact your local Trelawny dealer or agent. We always welcome feedback and comments from our valued customers.

General Information

Before operating, performing maintenance or repairing the TCG250 FLOOR GRINDER this manual must be read and understood by the operator, if in any doubt, ask your supervisor before using this equipment.

Local safety regulations must be followed at all times. Failure to follow these instructions could result in damage to the TCG250 and/or personal injury.

Trelawny SPT Limited disclaims all responsibility for damage to persons or objects arising as a consequence of incorrect handling of the machine, failure to inspect the machine for damage or other faults that may influence the operation prior to starting work, or failure to follow the safety regulations listed or applicable to the job site.

This machine is primarily designed for the smoothing of concrete, marble and terrazzo surfaces. It can be used both indoors and out.

Electric models are more suitable for indoor use because of the toxic exhaust gases that are produced by petrol engines.

Safety

WEAR SAFETY BOOTS, FACE MASK, SHATTERPROOF GLASSES, HELMET, GLOVES and any other personal protective equipment required for the working conditions. Avoid loose clothing; this may become trapped in moving parts and cause serious injury.

TO AVOID NUISANCE DUST, connect an industrial vacuum cleaner (minimum 3000watts or equivalent) to the 50mm (2") vacuum port situated at the rear of the machine.

ENSURE THAT THE WORK PLACE IS WELL VENTILATED. Avoid operating engine-powered machines in an enclosed area, since engine exhaust gases are poisonous.

BE VERY CAREFUL WITH HOT COMPONENTS. The exhaust and other parts of the engine are hot during operation and can remain hot for some time after shutdown.

DO NOT REFUEL THE ENGINE WHILE THE ENGINE IS HOT OR RUNNING, there is a very real danger from explosion – always refuel when the engine is cold, and in the open air.

During transportation fasten fuel cap tightly and close fuel tap.

DO NOT OPERATE ELECTRIC VERSIONS IN WET CONDITIONS.

CAUTION THIS MACHINE IS HEAVY. It weighs between (92kg/202lbs) and (144kg /317 lbs) dependent on power unit.

Do not lift this machine manually.

Risk of Hand-arm Vibration injury

These tools may cause Hand-arm Vibration Syndrome injury if their use is not adequately managed.

We advise you to carry out a risk assessment and to implement measures such as; limiting exposure time [i.e. actual trigger time, not total time at work], job rotation, ensuring the tools are used correctly, ensuring the tools are maintained according to our recommendations, and ensuring

that the operators wear personal protective equipment [PPE] particularly gloves and clothing to keep them warm and dry.

Employers should consider setting up a programme of health surveillance to establish a benchmark for each operator and to detect early symptoms of vibration injury.

We are not aware of any PPE that provides protection against vibration injury by attenuating vibration emissions.

See 'Specifications' section for vibration emission data.

Further advice is available from our Technical Department.

We strongly advise you to visit the Health & Safety Executive website <http://www.hse.gov.uk/vibration> This site provides excellent advice and information on HAV and currently, includes a Hand-arm Vibration Exposure Calculator that is easy to use to work out the daily vibration exposure for each of your operators.

Media Types & Applications

Grinding Blocks

All can be used wet or dry

Coarse grinding blocks

These are fitted as standard on machines fitted with the grinding block option. These are designed for the rapid removal of material. They produce a surface finish suitable for directly laying floor coverings or for two part epoxy paint coatings and for the first grind of terrazzo floor surfaces.

Medium grinding blocks

These are less aggressive than the coarse blocks, they should provide a surface finish suitable for painting or used as the next stage to the coarse grinding blocks, when achieving a polished surface on terrazzo tiles or other marble type surfaces.

Fine grinding blocks

These are the least aggressive of all the grinding media. These are generally only used for final finishing to provide a surface suitable for final polishing.

OPERATION

In addition, scarifying blocks and wire brushes are available which can be fitted in place of the grinding blocks.

Diamond Disc machine

The machine is fitted with a 20 segment diamond disc for medium concrete as standard (see below for specification). There are also 10 segment discs for very aggressive grinding and 16 segment discs for aggressive grinding available. The 20 segment disc are the most economical and least aggressive.

All discs can be used wet or dry.

Grinding disc 20 segment (Blue) (Soft bonded diamond)

Premium disc.

For medium to hard material, granite, cured concrete or terrazzo.

Grinding disc 20 segment (Black) (Medium bonded diamond)

Premium disc.

For medium or general abrasive materials - medium strength concrete or adhesives.

Grinding disc 20 segment (Red) (Hard bonded diamond)

Premium disc.

For softer or abrasive materials - green (less than 48hrs old) or medium strength concrete, or adhesives.

Pre-Start Check

ALL VERSIONS

Check all bolts and screws for tightness. Ensure that all fittings are secure.

Check the drive belts for correct tightness. There should normally be approximately 13mm (1/2") of free play when the belt is depressed in the middle position between the two pulleys.

To check and set the belt tension, refer to the *Belt installation & Adjustment* section.

The TCG250 is supplied with a specially commissioned electric motors and starter switch assembly.

Each unit is fully tested and the overload relays have been calibrated and set according to the manufactures specifications.

In the event of malfunction on a new machine, the owner should first check that the power supply on site is suitable and adequate. All cables should be fully uncoiled and never left wrapped around cable reels or tied in loops.

The starter box is fitted with a safety feature to protect the motor and relays from damage. Should an overload condition occur which triggers the thermal overload within the starter, depress the red stop button to reset.

Note that the circuitry may have to cool down for a period before the overload switch can reset itself upon depressing the stop button.

The starter boxes are preset and under no circumstances should they be tampered with, stripped down or adjusted, otherwise it will invalidate the warranty.

110v Motor

The motor requires the minimum of a 32amp, 110v power supply. Always use the shortest possible length of extension cable. To avoid voltage drop the cable must be a minimum core wire size of 2.5mm² but preferably 4.0mm² cross-section. The maximum length of cable can then be 15 metres and 30 meters respectively.

Use a centre tap transformer with a continuous rated output of at least 3.0KVA. In practice this means that a 5.0KVA transformer must be used. Manufacturers have different methods of rating their equipment.

All transformers and cables should be fitted with 32amp plugs and sockets.

The 230v supply to the 110v transformers ideally should be rated to at least 20amp if supply problems are to be avoided.

230v and 415v Motors

Take particular care when using 230v or 415v Machines, ensure that the electrical supply is earthed and that breakers and fuses are correct for the loading.

The 230v motor requires the minimum of a 13amp, 220v power supply.

The 415v motor requires the minimum of a 10amp, 380v power supply. Always use the shortest possible length of extension cable. To avoid voltage drop the cable must have a minimum core wire size of 2.5mm² cross-section. Maximum length of cable 30 meters.

ENGINE VERSIONS

CAUTION

Beware of **POISONOUS FUMES**.
Start and operate only in well-ventilated areas.

Starting

Machines fitted with petrol engines

The disc must be raised off the floor surface before starting the engine from cold.

The machine is fitted with a pedal operated stand to allow the disc to be raised off the ground when starting the engine.

Tilt the machine back by it's handle bar whilst depressing the pedal, keeping the pedal depressed, lower the machine back to the floor. The weight of the machine keeps the stand engaged and the head off the floor.

The engine may now be started. When starting from cold the throttle lever must be in the fast position to allow the automatic choke to operate. Subsequent starting may be carried out with the lever in the idle/slow position.

Once the engine is at operating temperature you may begin work. To retract the stand simply tilt the machine back.

See next section for detailed engine starting procedure.

Be careful with HOT COMPONENTS.

The exhaust and other engine parts are hot during and for some time after operation. Do not touch them.

OPERATION

Petrol engine starting procedure

Check that there is sufficient fuel in the fuel tank. (See manufactures hand book for type)

Check that the engine oil level is correct. (See pre-start check)

Ensure that the machine is started on a level surface.

Open the engine fuel tap.

For cold engine starting, the 5.5hp engines have an automatic choke, apply full throttle to operate.

Set the start switch to the "on" position on Honda supplied engines.

Check that the machine has been raised on its stand.

Pull the 'hold to run' lever against the handle bar.

Pull the recoil starter cord handle.

IMPORTANT

Do not pull the recoil starter cord to the end of its travel as it may cause damage to the engine or injury to the operator.

When the engine starts, recoil the cord slowly.

Do not allow the cord to snap back to its start position.

After the engine starts, move the throttle lever towards the idle/tick-over position until the engine runs smoothly.

After a minute or two reduce to a quarter open throttle setting and warm up the engine for a further 2~3 minutes before setting to tick over.

The warm up procedure is particularly important during cold weather.

Machines fitted with an electric motor

IMPORTANT:

Pull back on the handle bars to retract the machines stand, pull the 'hold to run' lever against the handle bar and press the green start button on the switch box, then gently lower the disc onto the surface being worked.

Machine Operation

(Please refer to manual handling recommendations when lifting.)

Connect a suitable commercial vacuum which has been designed for the collection of concrete dust and possibly toxic paint particles, or for use in the pharmaceutical or food industries, Trelawny can supply special HEPA filtered vacuums which are suitable for these applications.

Or if suitable for the area being worked, connect a water hose to the supplied connection at the rear of the machine.

: EMERGENCY SHUTDOWN :

Release the "Hold to run lever" on the handle bar and/or switch off the ignition switch on Honda engine versions.

On engine-powered machines,

once the engine has reached operating temperature and you are ready to start work, set the throttle lever to the full throttle position, pull back on the handle bars to retract the machines stand and slowly lower the disc to the surface.

The machine may oscillate slightly during use, which is normal. Move the machine slowly backwards and forwards, slightly swinging the grinding head right and left; this will ensure that a uniform finish is achieved.

Complete a small area noting the performance; on engine versions reduce the throttle to tick over and release the 'hold to run' lever.

Then on both engine and electric motor versions release the 'hold to run' lever to stop the machine, inspect the finish produced.

If necessary change the grade of grinding blocks or diamond discs and recheck performance and surface finish.

Shut Down

On electric powered machines, simply release the "hold to run" lever.

On engine powered machines, move the engine's throttle lever to the slow speed position. (This avoids the engine becoming washed internally by neat fuel if switched off from high engine revolutions.)

Release the 'hold to run' lever and on Honda engines, switch off the engine's start switch.

Important:

Close the engine fuel tap.

On both electric and engine powered machines, use the stand to raise the disc off the ground to prevent any built up heat deforming the rubber coupling if it is left under load whilst hot and stationary. The machine can be stored whilst on it's stand.

After the engine or motor has completely cooled, clean off any concrete dust from external components and remove any heavy build up of concrete dust from inside the front dust skirt, (See start of "**Grinding Block Replacement**" section for safe method of gaining access to inside of front dust skirt).

Take care when using hoses or pressure washers and clean within the dust skirt area only.

Do not to allow water to be directed at or splashed onto the engine, electric motor or any electrical components. Once clean and dry, cover the machine to protect it and store the grinder in a dry place.

Machine Storage

Long period storage: over 3months

Clean outside of machine, inspect the grinding blocks for wear; replace any worn parts as required.

Remove any build up of material from inside of grinding disc area following step in start of "**Grinding Block Replacement**" Section .

Cover the machine to protect it. Store the machine in a dry place.

Be sure to check security of wooden wedges after any lay up period.

MAINTENANCE

Belt Installation & Adjustment

Removal

Remove the top cover by unscrewing the two 8mm bolts either side of the chassis.

Loosen the engine/motor mounting plate bolts and slide the engine/motor forward. Slide the belt off the drive pulley and then remove it from the engine/motor pulley.

Installation

Slide the new belt onto the engine/motor pulley first, locating the belt in the pulleys teeth. Then slide onto into the teeth of the drive pulley.

Slide the engine/motor backwards until the slack in the belt is taken up, gently nip the four bolts and ensure the slack in the belt is correct (see note below). If the tension needs adjusting move the motor mounting plate in the desired direction until the correct tension is achieved.

Tighten all engine/motor mounting plate bolts fully, refit the top cover and tighten the 8mm bolts.

IMPORTANT

Normal slack should be approximately 13mm (1/2") when the belts are depressed in the middle position between the engine pulley and driveshaft pulley.

Drive system maintenance

The drive system on the TCG250 is virtually maintenance free and will give a long service life without attention providing the belt tension is set correctly.

The belt may need changing occasionally, the bearings (29) will require greasing after any lay up period and/or every 6 months or occasionally during heavy use.

Grinding Block Replacement

Switch off the engine powered versions and allow the engine to **cool completely**, disconnect electric motor powered versions from its power supply.

Place the machine on a flat and level surface.

Raise the front skirt by loosening the four 10mm guard retaining bolts on either side of the machine and slide the guard up to the top of the slots, tighten the bolts temporarily.

Tilt the machine backwards to rest on its handle bar.

Place a heavy object (10kg sand bag, etc.) across the upper part of the handle bar or tie down for additional security.

Take note how the grinding blocks and wedges have been assembled, using a suitable wooden drift, knock out the grinding block, not the wooden wedge.

Dispose of the used grinding blocks according to local legislation.

Fit each new grinding block squarely into the grinding plate location corner at the outer flat face of the grinding disc.

Secure with a new wooden wedge, between the block and the inner face of the grinding block, knock the wedge into position using a suitable drift.

Note:

Do not use a mix of old and new grinding blocks, this will cause rapid wear of the new blocks and could cause the machine to become uncontrollable, unstable and dangerous in use.

Re-adjust the lower guard and tighten the bolts.

Diamond Disc/Q.R. Plate Replacement

Switch off the engine powered versions and allow the engine to **cool completely**, disconnect electric motor powered versions from its power supply.

Place the machine on a flat and level surface.

Raise the front skirt by loosening the four 10mm guard retaining bolts on either side of the machine and slide the guard up to the top of the slots, tighten the bolts temporarily.

Tilt the machine backwards to rest on its handle bar.

Place a heavy object (10kg sand bag, etc.) across the upper part of the handle bar or rope down for additional security.

Remove the four countersunk M12 screws from the disc, ensuring that the disc is supported as the last two are removed. The disc now will come away from the drive plate.

Dispose of the used item according to local legislation.

Offer the new disc up to the drive plate and align the holes. Loosely fit the four bolts and then tighten in a diagonal sequence to 40lb/ft.

Re-adjust the lower guard and tighten the bolts

Brush Seal Replacement

The machine is fitted with a flexible brush seal which will need replacement from time to time to maintain the efficiency of the dust control system. Follow the first five steps from the above procedure for changing discs. Drill out rivets and to remove the brush simply grasp one end and pull, the brush will come off the guard.

To fit the new brush, align one end of the brush with the end of the guard and use a suitable drift to knock the brush onto the metal guard, working along until it is securely fitted.

TROUBLESHOOTING

FAULT	CAUSE	ACTION
Engine stops suddenly or does not run correctly	No fuel in the fuel tank.	Refuel fuel tank. (See safety section.)
	Spark plug faulty.	Replace spark plug.
	Fuel blockage.	Check fuel line and strainer.
	Air filter partially blocked.	Replace air cleaner element.
Motor stops suddenly or does not run correctly	Loose wiring, incorrect voltage, or blown fuse.	Check connections and power supply or replace fuse.
Engine/motor runs but the grinding heads do not move.	Drive Belts slack or failed.	Replace Belt or adjust tension.
	Sheared drive key/ loose taperlock bush	Replace key and re-torque taperlock bush.
Grinder is slow or erratic	No grinding blocks fitted	Check grinding discs for any damage, replace if necessary. Fit new grinding blocks.
	Loose or a failed drive belts.	Adjust drive belt, or replace.
	Surface too rough.	Use Trelawny TFP200/250 surface Planer to produce a smoother surface or to remove bulk of material prior to grinding. Change grinding blocks to a coarser grade.
Engine will not start	No fuel in the fuel tank	Refuel fuel tank, see safety precautions.
	Water in fuel	Drain fuel tank, float chamber, and refuel.
	Incorrect fuel in tank, i.e. diesel in petrol tank	Clean out fuel tank, all fuel lines and carburettor float chamber. Refuel with correct fuel.
	Spark plug faulty	Replace spark plug.
Motor will not start	Power supply is not switched on, blown fuse, voltage incorrect, loose wiring, or faulty motor.	Confirm that the power supply is switched on. Rectify loose wiring, replace blown fuse or replace motor.
Use above information in conjunction with the Honda / Briggs and Stratton Operation and Maintenance Manual.		
If problem has not been cured by any of the above actions, contact your local Trelawny SPT dealership for assistance.		

EXPLODED VIEW

Notes

- Any items not numerically identified are duplicates of identified items.
- Parts 23-28 are variable dependant on model. (See additional table on page 12)
- Part 42 may be a 'Grinding Block Holding Plate' (350.00CDDR) dependant on your model, if this is the case your machine will not have Part 41.
- Horse shoe weight, part 47 is an optional extra.
- Model specific items are shown in a separate table on page 11.
- **Not shown:** Motor/engine and associated fasteners, starter box/throttle lever assembly and safety switch, stand return spring, water hose and brush seals. (See table for part numbers and details)

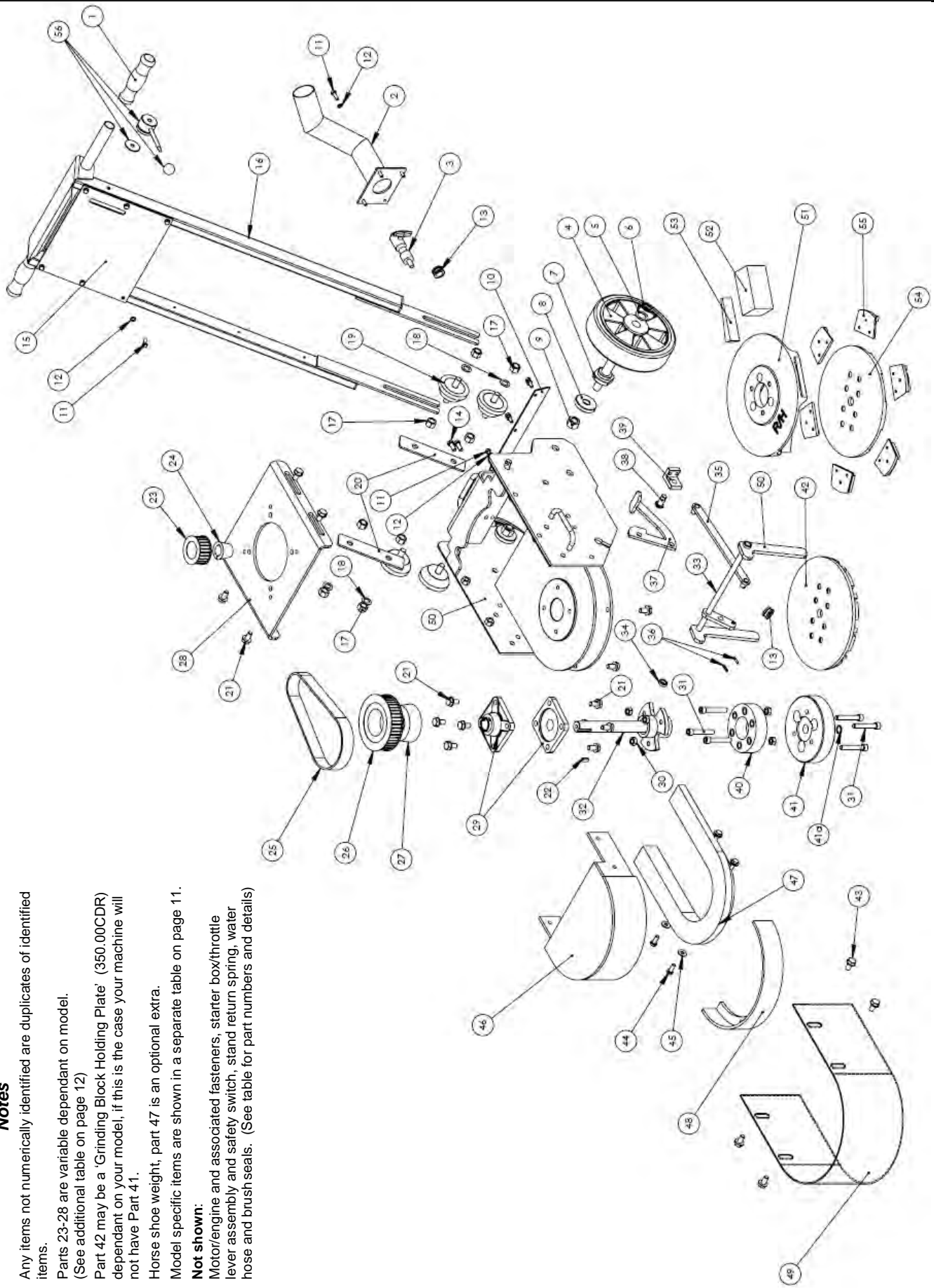

PARTS LIST

Item	Part No.	Description	Item	Part No.	Description
1	822.2000	Rubber grip (x2)	44	831.0820	M8 x 20 hex bolt
2	345.9220	Vacuum takeoff tube	45	811.1008	M8 shake proof washer
3	828.0138/ 826.0183/ 819.0385	3/8" ball valve/ bulkhead connector/ hose tail	46	345.9223	Belt guard
4	350.9121	Wheel (x2)	47	345.2012	Weight
5	812.1001	20mm plain washer (x2)	48	345.2011	Removable section
6	814.1020	External circlip (x2)	49	345.9221	Dust skirt
7	345.9241	Stub axle (x2)	50	345.2010	Chassis
8	812.1016	M16 washer (x2)	51	350.00CDR	R/H Grinding Block Mounting Plate
9	824.1600	M16 Nyloc nut (x2)	52	350.5509	Abrasive Block (Coarse)
10	345.9222	Rear dust skirt		350.5505	Abrasive Block (Fine)
				350.5507	Abrasive Block (Medium)
11	831.0620	M6 x 20 hex bolt		350.5519	Wire brush
12	811.1006	M6 shake proof washer		350.5525	Scarifying Block
13	843.0808	Water hose grommet	53	350.5502	Wedge
14	831.0820/ 811.1008	M8 x 20 hex bolt M8 shake proof washer	54	350.5660	6 Segment Quick Fit Plate
15	345.9232	Starter box/throttle mounting plate	55	See Page 13/14	Quick Fit Plate Tooling
16	345.9230	Complete handle assembly	56	350.9180 350.9186	Throttle lever (petrol only) Ball
17	834.0500	1/2" UNF nyloc nut (x8)			
18	812.0500	1/2" plain washer (x4)	Items not shown on exploded view		
19	830.2000	Rubber mount 1/2" UNF		See page 13	Motor/engine
20	345.9231	Handle clamping plate		345.9560A	230v Motor extension
21	831.1030/ 811.1010	M10 x 30 hex bolt M10 shake proof washer (x12)		320.7110	110v starter assembly
22	350.9150	Drive key 8 x 7 x 25		320.7112	230v starter assembly
23	See page 13	Motor pulley		320.7114	415v starter assembly
				350.9175	Throttle cable (petrol only)
24	See page 13	Taper lock bush (motor)		719.3000	Water hose (request 0.4M)
25	See page 13	Drive belt		345.9828	Deadmans complete switch assembly
26	See page 13	Drive shaft pulley		345.9826	Deadmans upper switch inc lever
27	See page 13	Taper lock bush (drive shaft)		345.9800	Deadmans switch box (No lever)
28	345.9224 345.9225	Motor mounting plate for all other models Motor mounting plate for 345.2000, 345.2000D and 345.2004D		731.3154	Front brush seal
29	350.9116	25mm bearing assembly (x2)		731.3155	Rear brush seal
30	824.1000 824.1200	M10 nyloc nut (x6) M12 nyloc nut (x6) (for 345.2000D)		713.5060	Stand return spring
31	806.1060 806.1260	M10x60 cap head bolt (x6) M12x60 cap head bolt (x6) (for 345.2000D)		350.9141	M12 x 25 c/sunk socket screw x4
32	345.9235	Drive shaft (for 345.2000D)		320.9126D	Honda engine pulley for woodruff key type shaft (N1)
33	345.9207A	Pedal operated stand assembly		320.9126E	Honda pulley extension for N1 type shaft
34	345.9208	Shaft bush (x2)			
35	345.9204	Connecting rod			
36	813.0420	4mm roll pin			
37	345.9201	Pedal			
38	345.9203	Pivot pin			
39	345.9202	Pedal bracket			
40	350.9146	Rubber coupling (for 345.2000D)			
41	350.9143A	Diamond plate adapter			
41a	809.3005	O-ring			
42	350.5620G	20 Segment diamond disc			
43	320.9234 811.1010	M10 x 20 hex bolt M10 shake proof washer			

ITEM	Part Number	DESCRIPTION	ITEM	Part Number	DESCRIPTION
OTHER PARTS NOT SHOWN IN EXPLODED VIEW			230v Lovato Starter Box Components		
	320.7110	110v starter assembly		841.2616	Contactora (Lovato) 230v
	320.7112	230v starter assembly		841.2625	Overload Relay 230v/415v 4-6.5amp
	320.7114	415v starter assembly		841.2621	Start Contact (Lovato) all versions
				841.2104	230v Panel Mounting Plug (Blue)
	841.2102	110v 32amp Lead Plug (Yellow)			
	841.2104	240v 16amp Lead Plug (Blue)	415v Lovato Starter Box Components		
	841.2106	415v Lead Plug (Red)		841.2617	Contactora (Lovato) 415v
				841.2625	Overload Relay 230v/415v 4-6.5amp
				841.2621	Start Contact (Lovato) all versions
110v WEG Starter Box Components				841.2106	415v Panel Mounting Plug (Red)
	841.2640	110v Starter Box & Lid inc Buttons			
	320.7130	110v Panel Mounting Plug (Yellow)			
230v WEG Starter Box Components					
	841.2642	230v/415v Starter Box & Lid inc Buttons			
	841.2640A	Overload Relay 230v only (RW27D17)	Lafert Motor Components (see exploded view page 15)		
	841.2640B	Contactora (CWM18.10 230v only)	14	841.2650	Icar or Ducati start capacitor (Black)
	320.7132	230v Panel Mounting Plug (Blue)	14	841.2660	Facon or Ducati run capacitor (White)
			5	841.2670	SE01 Electronic starter switch
			24	841.2680	Fan
415v WEG Starter Box Components			22	841.2690	Fan Cover
	841.2642	230v/415v Starter Box & Lid inc Buttons	9/11	841.2694	Terminal box and lid
	841.2106	415v Panel Mounting Plug (Red)			
			Others not show in exploded view		
				345.9828	Deadmans complete switch assembly
110v Lovato Starter Box Components				345.9826	Deadmans upper switch inc lever
	841.2615	Contactora (Lovato) 110v		345.9800	Deadmans switch box (No lever)
	841.2620	Start Contactora (Lovato) 110v		320.9300	M5 x 50 Screws for Deadmans Handle x 2 required
	841.2624	230/415v Overload Relay 4/6.5amp		320.9305	M5 Nyloc Nuts for Deadmans Handle x 2 required
	841.2621	Start Contact (Lovato) all versions		320.9310	M5 Plain Washer x 4 required
	841.2102	110v Panel Mounting Plug (Yellow)		320.9150	Spacer Plate (Electric) x 2 required

PARTS LIST model specific

Model variant by part number (D=Diamond Disc)	Motor/engine/starter N4 shaft prior to 2014	Motor bolts	Motor nuts	Motor washers
345.2000 5.5HP petrol	350.9500 Honda N4 shaft 345.9500 Honda N1 shaft	806.5610 (x2)	824.0810 (x2)	811.1008 (x8)
345.2000D 5.5HP petrol	350.9500 Honda N4 shaft 345.9500 Honda N1 shaft	806.5610 (x2)	824.0810 (x2)	811.1008 (x8)
345.2002 110V 1ph 1.8Kw	345.9550 motor 320.9143 starter	831.1240 (x4)	824.1200 (x4)	811.1012 (x8)
345.2002D 110V 1ph 1.8Kw	345.9550 motor 320.9143 starter	831.1240 (x4)	824.1200 (x4)	811.1012 (x8)
345.2004 230V 1ph 2.2kW	345.9565 motor 320.9147 starter	831.1240 (x4)	824.1200 (x4)	811.1012 (x8)
345.2004D 230V 1ph 2.2Kw	350.9560 motor 320.9147 starter	831.1040 (x4)	824.1000 (x4)	811.1010 (x8)
345.2006D 415V 3ph 5.5Kw	350.9575 motor 325.9186 starter	831.1240 (x4)	824.1200 (x4)	811.1012 (x8)

Drive components by model

Taper Lock bushes include new grub screws (Not illustrated) for fitting
Also supplied with data sheet with torque setting and method.

The TCG250 is available in a range of configurations.
The appropriate drive components for each variant are listed in the table below.

Note:
Honda N1 type shaft has a v-belt pulley arrangement and is not a taper lock pulley, this item has to be purchased as an assembly.

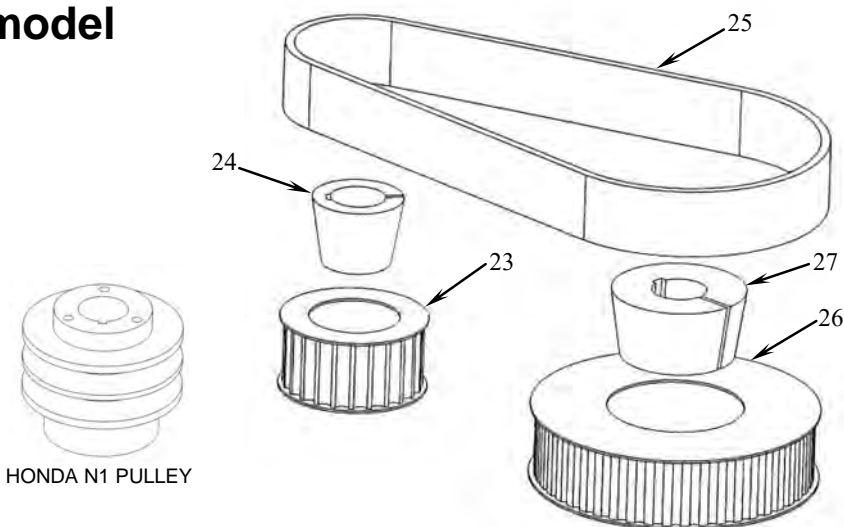

HONDA N1 PULLEY

Model variant by part number	(23) PULLEY (MOTOR)	(24) TAPER LOCK BUSH (MOTOR)	(25) BELT	(26) PULLEY (DRIVESHAFT)	(27) TAPER LOCK BUSH (DRIVESHAFT)
345.2000	345.9130 Honda N4 345.9126A Honda N1	345.9129A N4 See (23) N1	345.9136 Honda N4 345.9126V Honda N1	345.9134 Honda N4 345.9126D Honda N1	345.9126M Honda
345.2000D	345.9130 Honda N4 345.9126A Honda N1	345.9129A N4 See (23) N1	345.9136 Honda N4 345.9126V Honda N1	345.9134 Honda N4 345.9126D Honda N1	345.9126M Honda
345.2002	345.9130	345.9129A	345.9136	345.9134	345.9126
345.2002D	345.9130	345.9127A	345.9135	345.9123	345.9125
345.2004	345.9133	345.9129B	345.9137	345.9134	345.9126
345.2004D	345.9127A	345.9127A	345.9135	345.9124	345.9124A
345.2006D	345.9127	345.9128	345.9136	345.9124	345.9124B

Media Types - Metal Bond Tools

Image	Part Number	Tool Description
	365.5495L	PCD Removal Diamond Anti Clock Wise For removal of coatings, adhesives & toppings
	365.5495R	PCD Removal Diamond Clock Wise For removal of coatings, adhesives & toppings
	365.5500	16 Grit Single (Quick Release) Soft Bond For very course grinding and thin coating removal
	365.5500/2	16 Grit Double (Quick Release) Soft Bond For very course grinding and thin coating removal
	365.5501	30 Grit Single (Quick Release) Soft Bond For Hard Concrete
	365.5502	30 Grit Single (Quick Release) Medium Bond For Medium Hardness concrete
	365.5503	30 Grit Single (Quick Release) Hard Bond For Soft Concrete or for very rough concrete
	365.5501/2	30 Grit Double (Quick Release) Soft Bond For Hard Concrete
	365.5502/2	30 Grit Double (Quick Release) Medium Bond For Medium Hardness concrete
	365.5503/2	30 Grit Double (Quick Release) Hard Bond For Soft Concrete or for very rough concrete
	365.5504/2	70 Grit Double (Quick Release) Medium Bond For Light Grinding and Scratch Removal
	365.5506/2	120 Grit Double (Quick Release) Medium Bond For Light Grinding and Scratch Removal

Media Types - Resin Bond Tools

Image	Part Number	Tool Description
	365.5605	50 Grit Hybrid
	365.5610	100 Grit Hybrid
	365.5620	200 Grit Hybrid
	365.5602A	200 Grit Resin Bond
	365.5604A	400 Grit Resin Bond
	365.5608A	800 Grit Resin Bond
	365.5618A	1500 Grit Resin Bond
	365.5635A	3000 Grit Resin Bond
	350.5666	Polishing Adapter Plate Used to attach the "Polishing Tools" to the quick release plate

AmTec 230v 4 pole motor wiring diagram (For use with blocks)

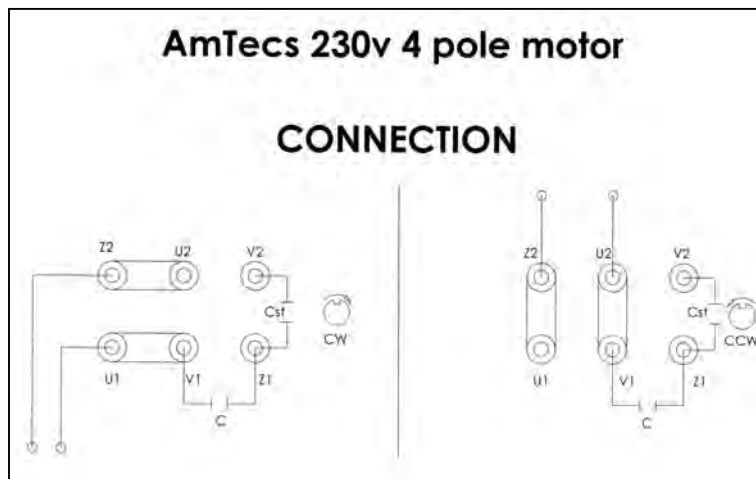

LAFERT ELECTRIC MOTOR EXPLODED VIEW

110v & 230v Motors

Only the most commonly used motor components are carried in stock at Trelawny SPT Ltd.

These items are listed under the Lafert Motor heading in the parts list on the previous page.

Note:

Endsheild Drive End Flange not shown in item 3.

Items 27,28,29 & 30 are not used on the Grinder.

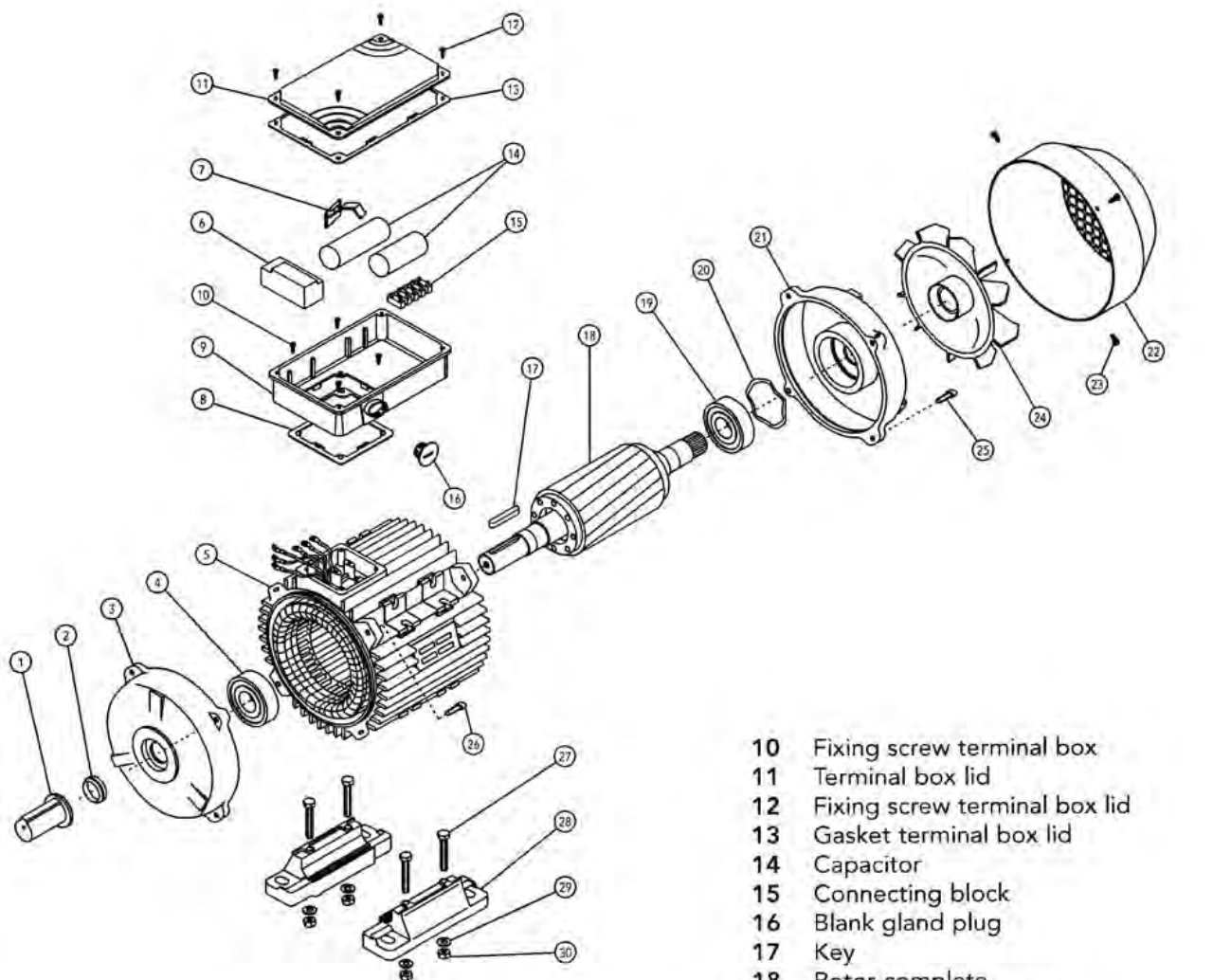

PART DESCRIPTION

- | | | | |
|---|-------------------------|----|-------------------------------------|
| 1 | Shaft protection | 10 | Fixing screw terminal box |
| 2 | Dust seal drive end | 11 | Terminal box lid |
| 3 | Endshield drive end | 12 | Fixing screw terminal box lid |
| 4 | Bearing drive end | 13 | Gasket terminal box lid |
| 5 | Stator frame | 14 | Capacitor |
| 6 | Starter | 15 | Connecting block |
| 7 | Fixing device capacitor | 16 | Blank gland plug |
| 8 | Gasket terminal box | 17 | Key |
| 9 | Terminal box | 18 | Rotor complete |
| | | 19 | Bearing non-drive end |
| | | 20 | Pre-load washer |
| | | 21 | Endshield non-drive end |
| | | 22 | Fan cover |
| | | 23 | Fixing screw fan cover |
| | | 24 | Fan |
| | | 25 | Fixing bolt endshield non-drive end |
| | | 26 | Fixing bolt endshield drive end |
| | | 27 | Fixing bolt motor feet |
| | | 28 | Motor feet |
| | | 29 | Fixing washer motor feet |
| | | 30 | Fixing nut motor feet |

WIRING DIAGRAMS

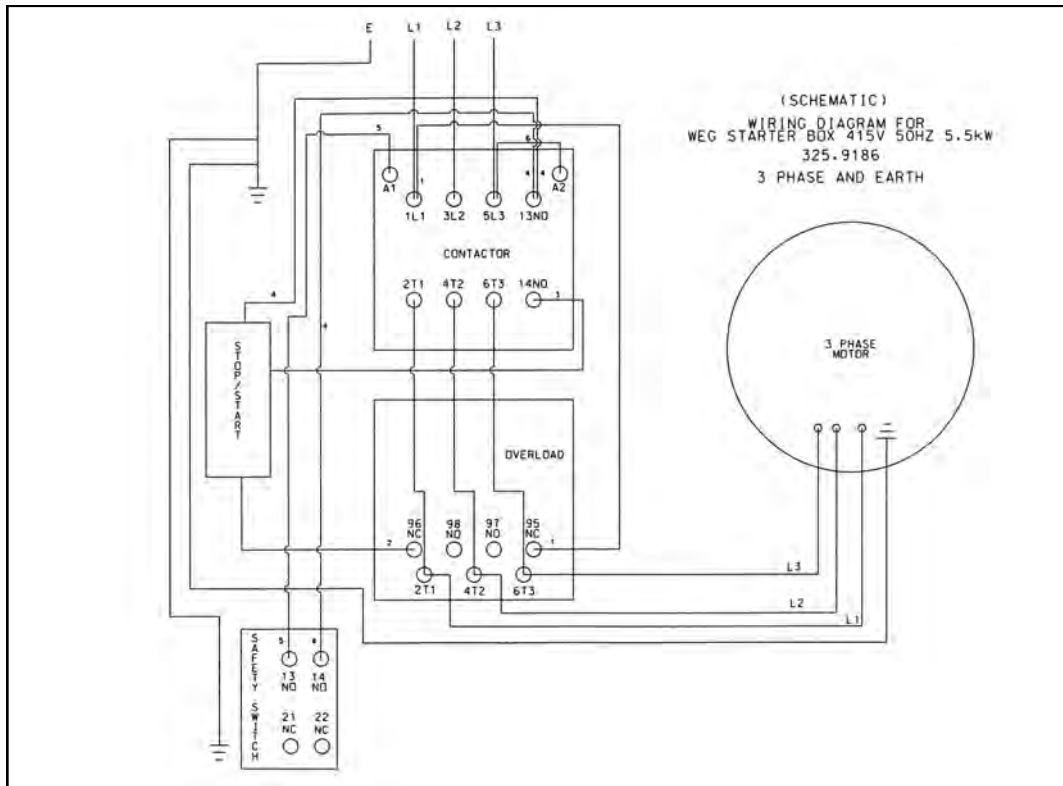
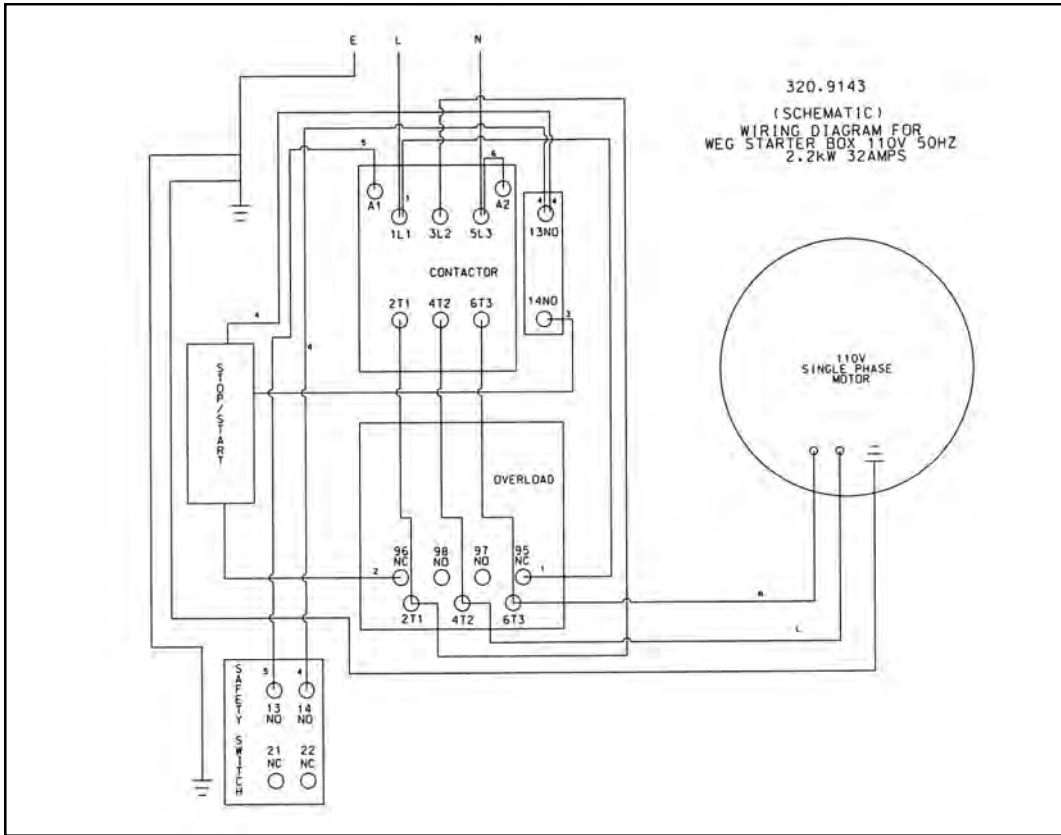

WIRING DIAGRAMS

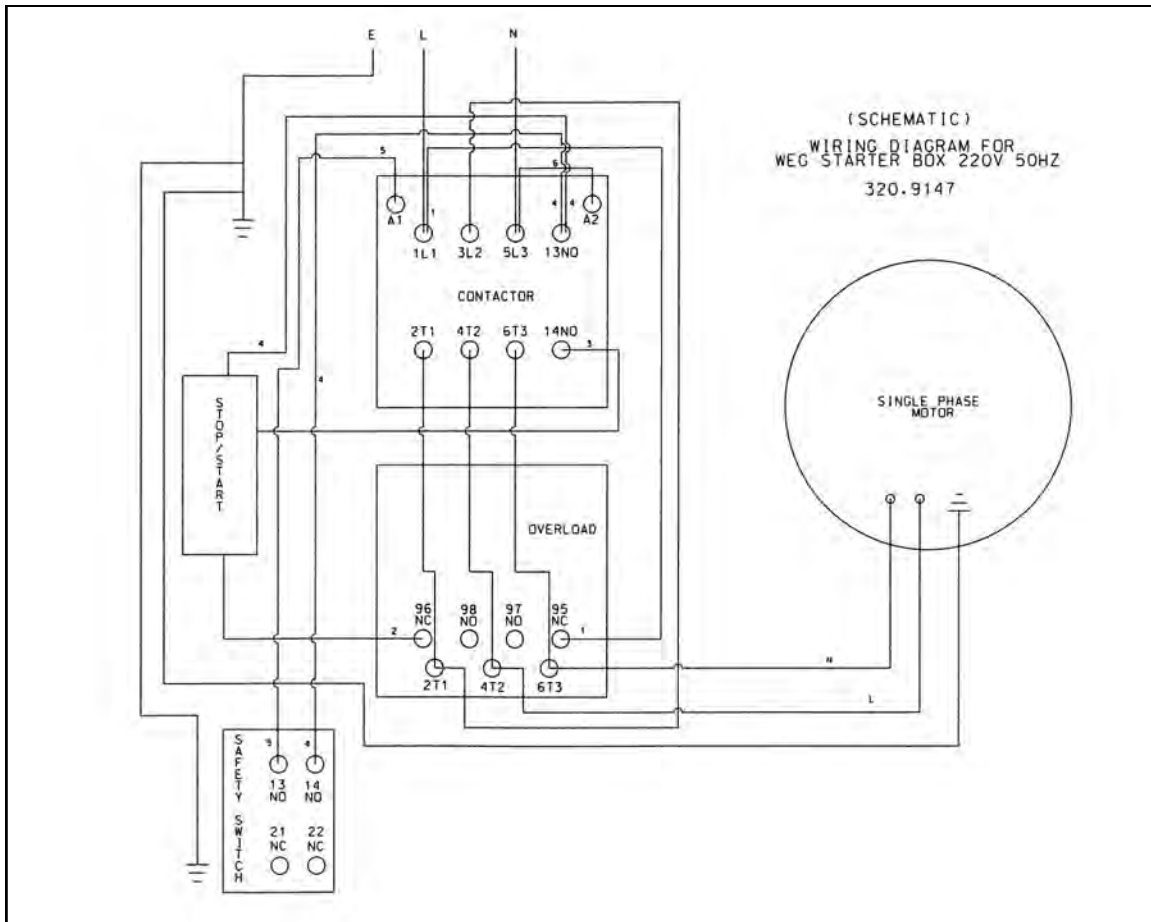

GAMAK ELECTRIC MOTOR 220V

To change direction of rotation
swap main winding leads (Black/Brown)
at terminals U1 and U2

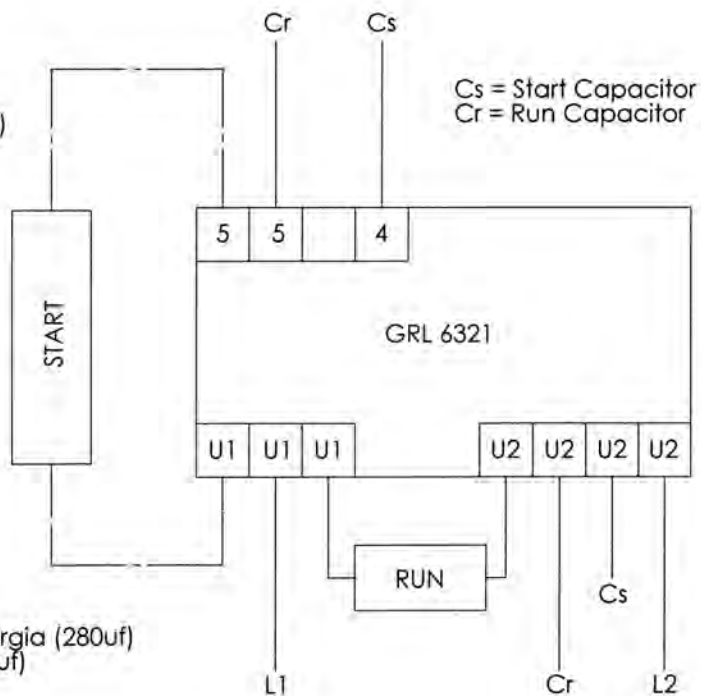

Capacitors

841.2750 - Black: Mortorstart Ducati Energia (280uf)

841.2760 - White: Micronkon CBB60 (60uf)

841.2770 - Gamak Switch: GRL6312

STARTER BOX WIRING DIAGRAMS (LOVATO)

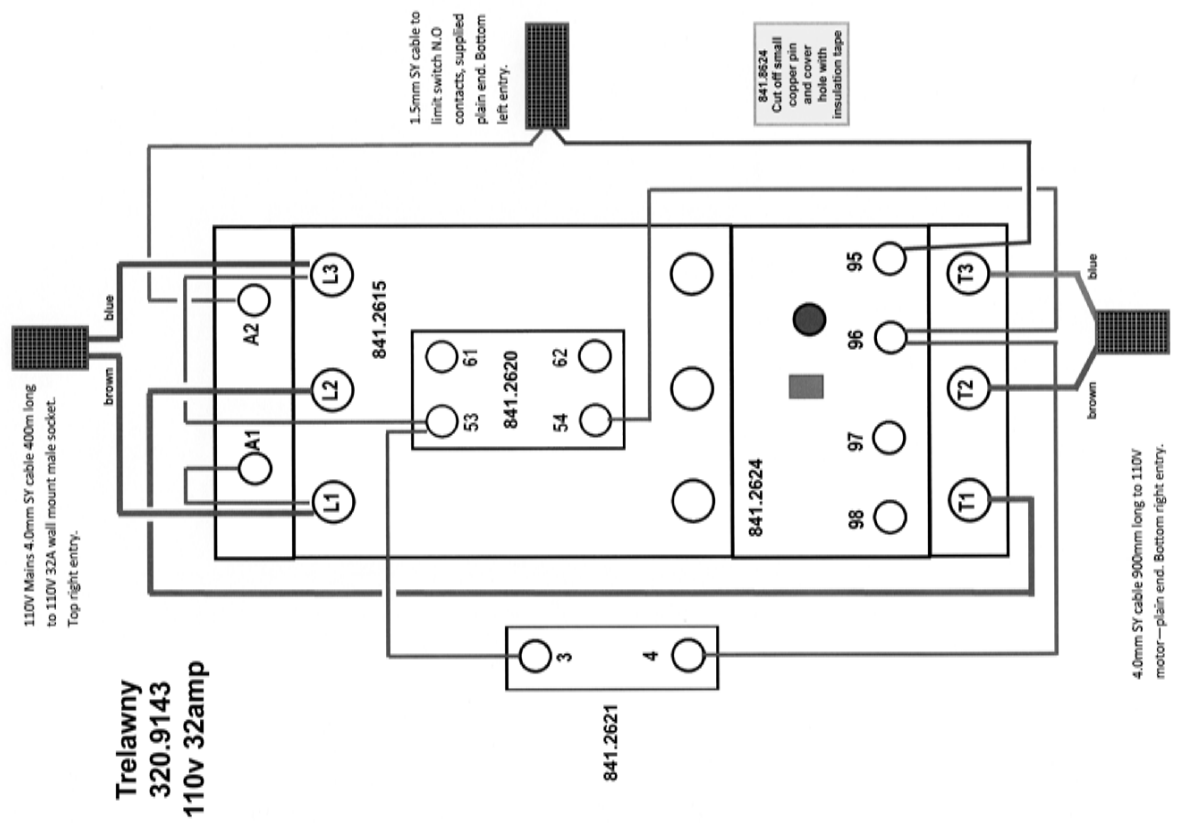
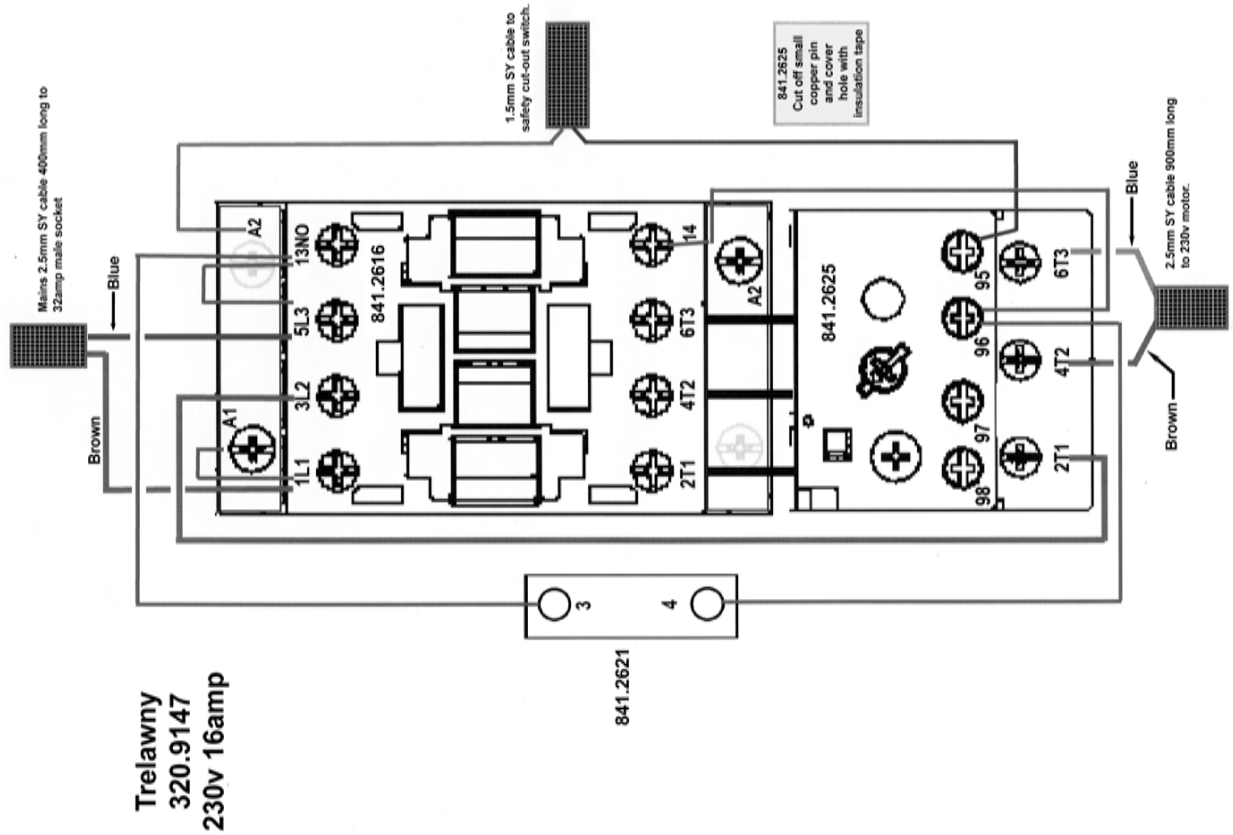

STARTER BOX WIRING DIAGRAMS (LOVATO)

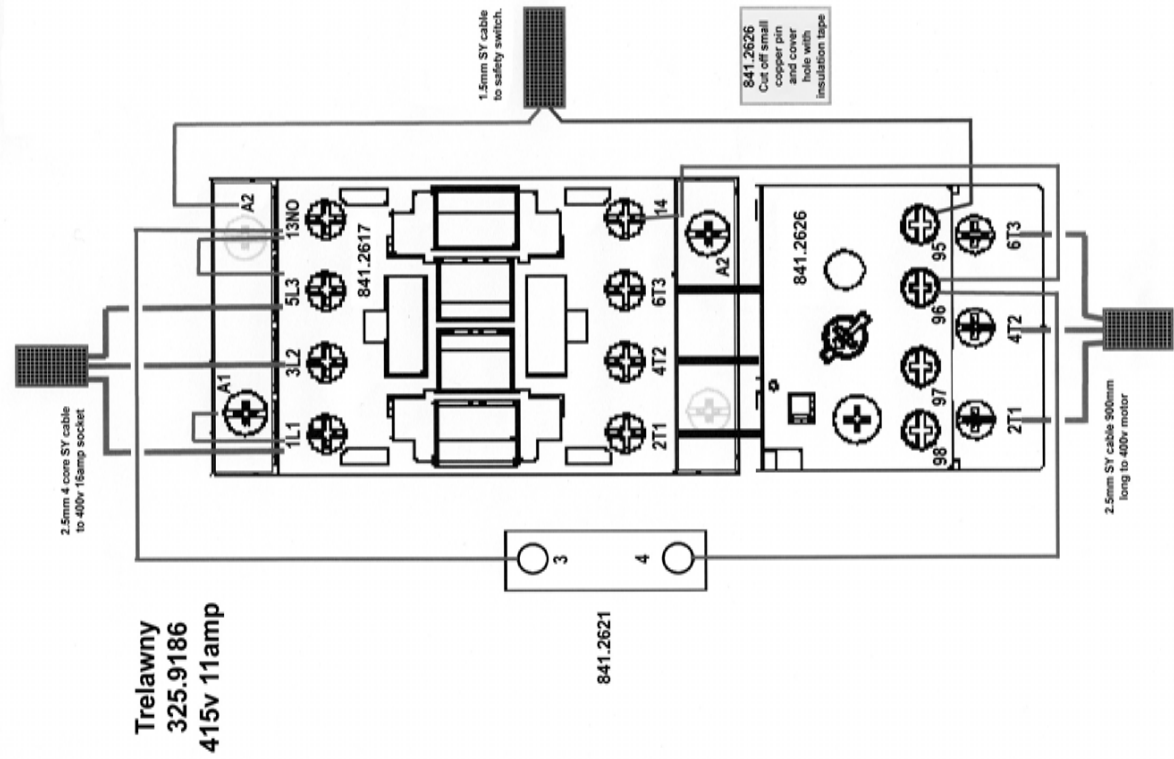
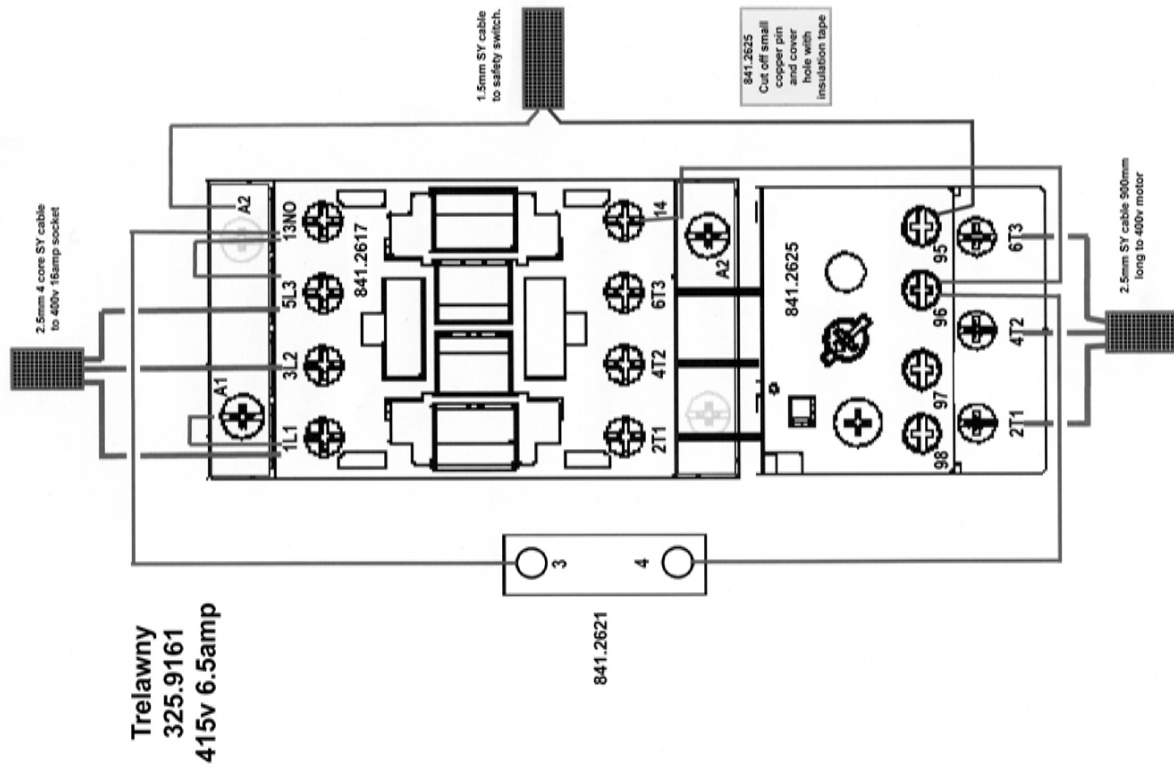

TECHNICAL SPECIFICATIONS

Length x Width x Height (inc handle and wheels)	1100mm x 450mm x 980mm	43.3" x 17.7" x 38.6"	
Cutting width	254mm	10 inch	
Average depth of cut (dependent on concrete)	1 mm	0.040 inch	
Electric motors	400v	230v	110v
Power	5.5kW (7.5hp)	2.2kW (3.0hp)	1.8kW (2.4hp)
Voltage	400v (3ph)	230v (1ph)	110v (1ph)
Supply	11amp	16amp	32amp
Disc speed - rpm approximately	1600	1425	860
Petrol engines: Honda GXV160	Unleaded petrol - disc speed variable dependant on throttle opening		
Weight	Electric motor	90kg	(198lbs)
	5.5hp Petrol engine	87kg	(192lbs)
Working distance from wall	25mm side / 20mm front	1.0" side / 3/4" front	
Electric motor Noise L_{WA} SWL	86.04dB (A)		
Honda Engine 5.5hp	91.5dB (A)		

Declared Noise emissions in accordance with EN ISO 15744: 2008

	Carborundum Blocks	Diamond Disc
Vibration (AEQ) at the Handle Bar (110v Electric)	Aeq = 2.36 m/s ² (k)	Aeq = 1.25 m/s ² (k)
Vibration (AEQ) at the Handle Bar (230v Electric)	Aeq = 1.17 m/s ² (k)	Aeq = 0.913m/s ² (k)
Vibration (AEQ) at the Handle Bar (415v Electric)	Aeq = 2.75 m/s ² (k)	Aeq = 2.34 m/s ² (k)
Vibration (AEQ) at the Handle Bar (Petrol Models)	Aeq = 5.61 m/s ² (k)	Aeq = 6.35 m/s ² (k)
(K= +40% -0%)		
Noise level measured in accordance with	EN ISO 15744: 2008	
Vibration measured in accordance with	EN ISO 28927:2012 & EN ISO 20643:2005	

Machinery Directive Information

This tool has been designed and produced in accordance with the following directives:

2006/42/EC Machinery Directive

If your company has any problem with our products or would like to discuss the possibility of an improvement being made to them, then please do not hesitate to contact us. Your comments are both important and appreciated.

All rights reserved. Any unauthorised use or copying of the contents or part thereof is prohibited.

This applies to trademarks, model denominations, part numbers and drawings.

Use only genuine Trelawny spares.

The use of non-Trelawny spare parts invalidates the warranty.

Trelawny SPT Ltd
13 Highdown Road, Sydenham Industrial Estate, Leamington Spa,
Warwickshire, CV31 1XT, United Kingdom
Telephone: +44 (0)1926 883781 - Fax: +44 (0)1926 450352
Email: sales@trelawny.co.uk

© TSPT UK 2013 Part No: 735.5270 issue 11.11.16



www.trelawnyspt.co.uk